

FOR LEASE

Retail Space
North Austin, Texas



2121 Parmer Lane

Availability: Immediate

Location: Near the intersection of Parmer Lane and Metric Blvd in North Austin

Size: Suites sizes available from 1,080 sq ft to 5,5200 sq ft.

Lease Rate: First year rate \$15.50 per sq. ft. plus NNN of 4.35 for year 2011



ROBERT R. HEMPHILL, CCIM

COMMERCIAL REAL ESTATE

512-474-2224

roberthemphill@austin.rr.com

<http://www.weleaseaustin.com/listings.htm>

All information regarding this property is from sources deemed reliable, however, Broker has not made an independent investigation of these sources and no warranty or representation is made by the Broker as to the accuracy thereof and same is submitted subject to errors, omissions, change of price, rental or other conditions, prior sale, lease or withdrawal from market without notice. Broker further has not made and shall not make any warranty or representation as to the condition of the property nor the presence of any hazardous substances or any environmental or other conditions that may affect the value or suitability of the property.

1300 West Lynn, Suite 110, Austin, Texas 78703, (512) 474-2224 fax: (512) 474-4224

FOR LEASE

Retail Space
North Austin, Texas

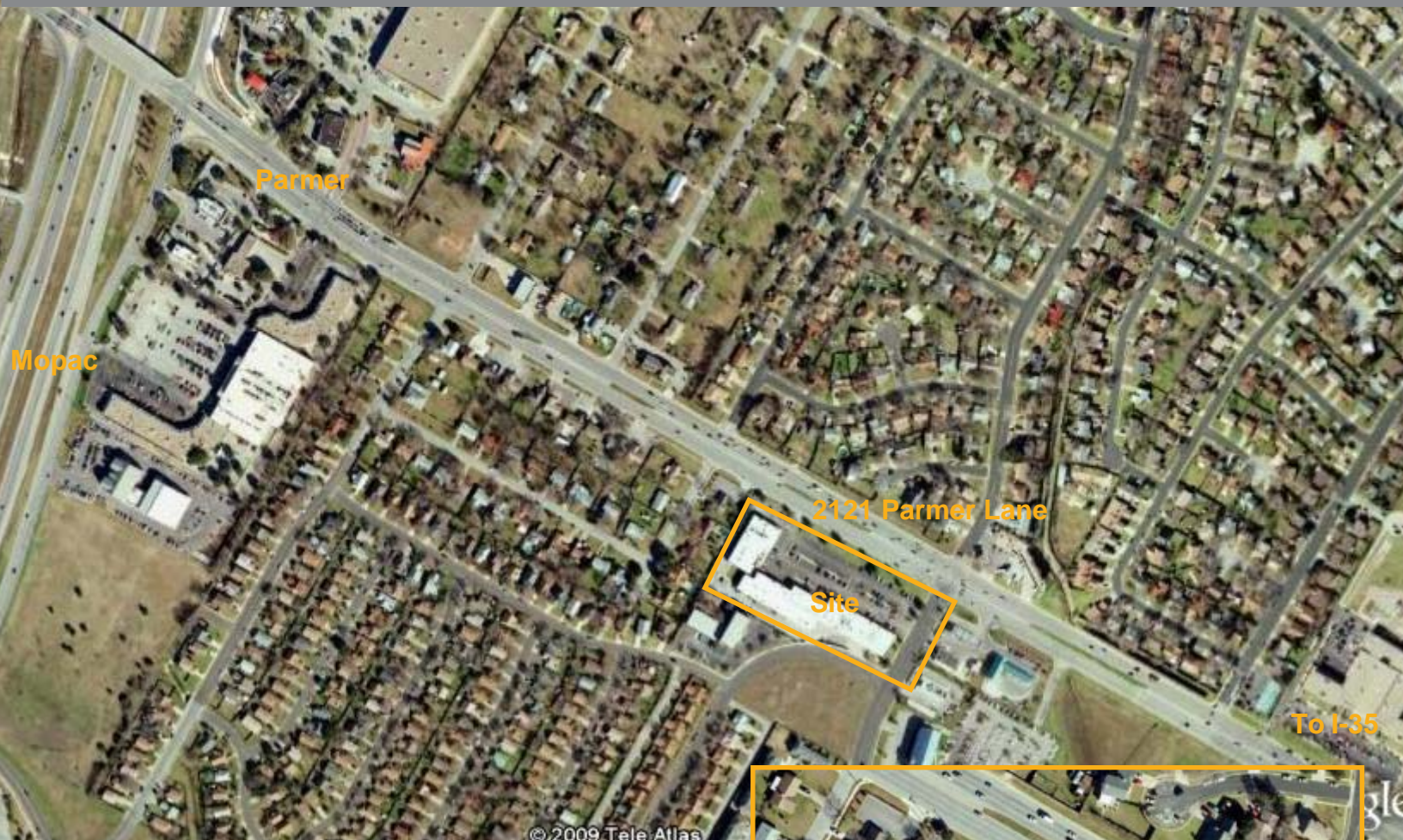

2121 Parmer Lane

Availability: Immediate

Location: Near the intersection of Parmer Lane and Metric Blvd in North Austin

Size: Suites sizes available from 1,080 sq ft -to 5,520 sq ft.

Lease Rate: First year rate \$15.50 per sq. ft. Plus \$4.35 NNN for year 2011



roberthemphill@austin.rr.com
<http://www.weleaseaustin.com/listings.htm>

All information regarding this property is from sources deemed reliable, however, Broker has not made an independent investigation of these sources and no warranty or representation is made by the Broker as to the accuracy thereof and same is submitted subject to errors, omissions, change of price, rental or other conditions, prior sale, lease or withdrawal from market without notice. Broker further has not made and shall not make any warranty or representation as to the condition of the property nor the presence of any hazardous substances or any environmental or other conditions that may affect the value or suitability of the property.

1300 West Lynn, Suite 110, Austin, Texas 78703, (512) 474-2224 fax: (512) 474-4224

FOR LEASE

Retail Space
North Austin, Texas

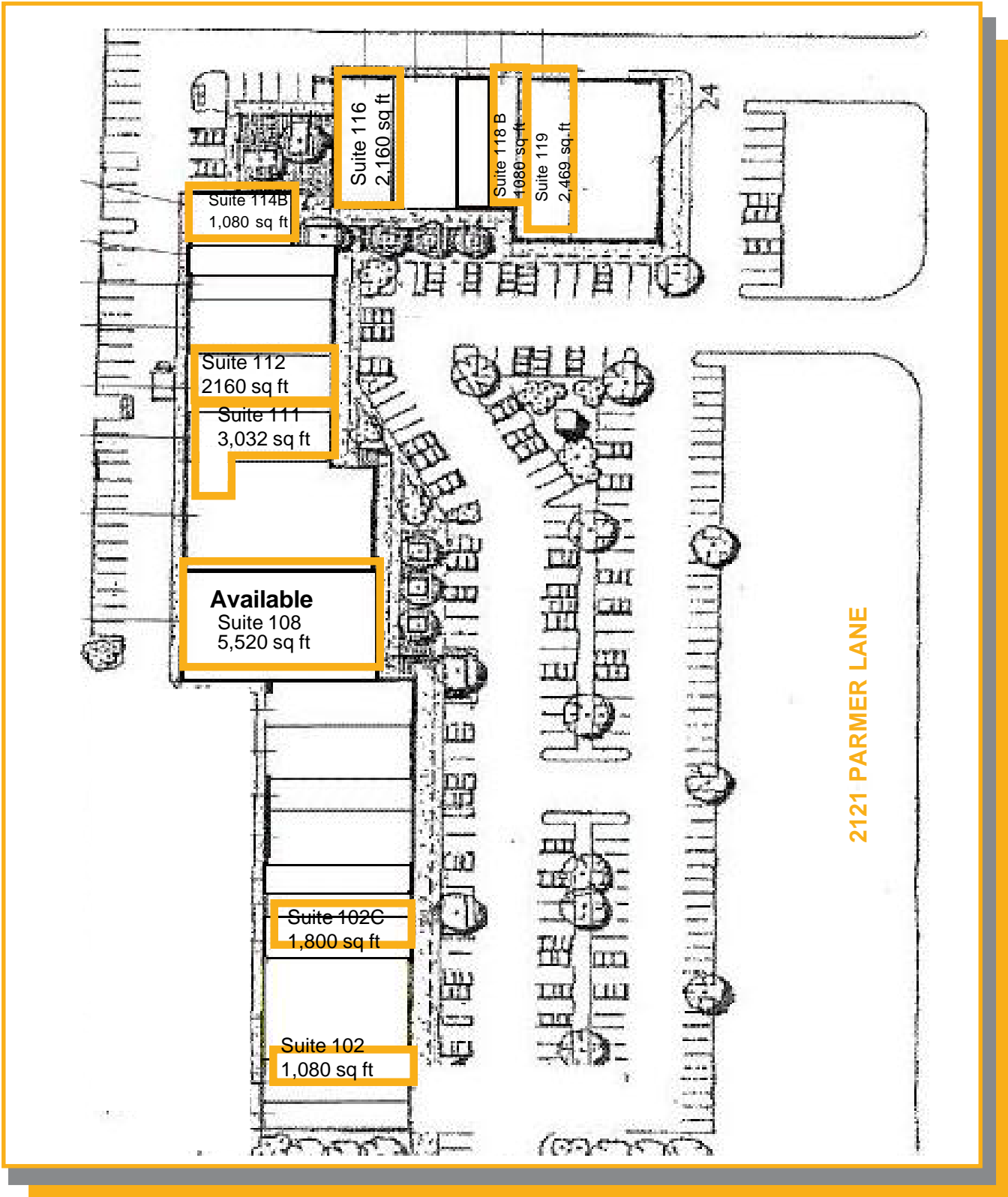

All information regarding this property is from sources deemed reliable, however, Broker has not made an independent investigation of these sources and no warranty or representation is made by the Broker as to the accuracy thereof and same is submitted subject to errors, omissions, change of price, rental or other conditions, prior sale, lease or withdrawal from market without notice. Broker further has not made and shall not make any warranty or representation as to the condition of the property nor the presence of any hazardous substances or any environmental or other conditions that may affect the value or suitability of the property.



FOR LEASE

Retail Space
North Austin, Texas

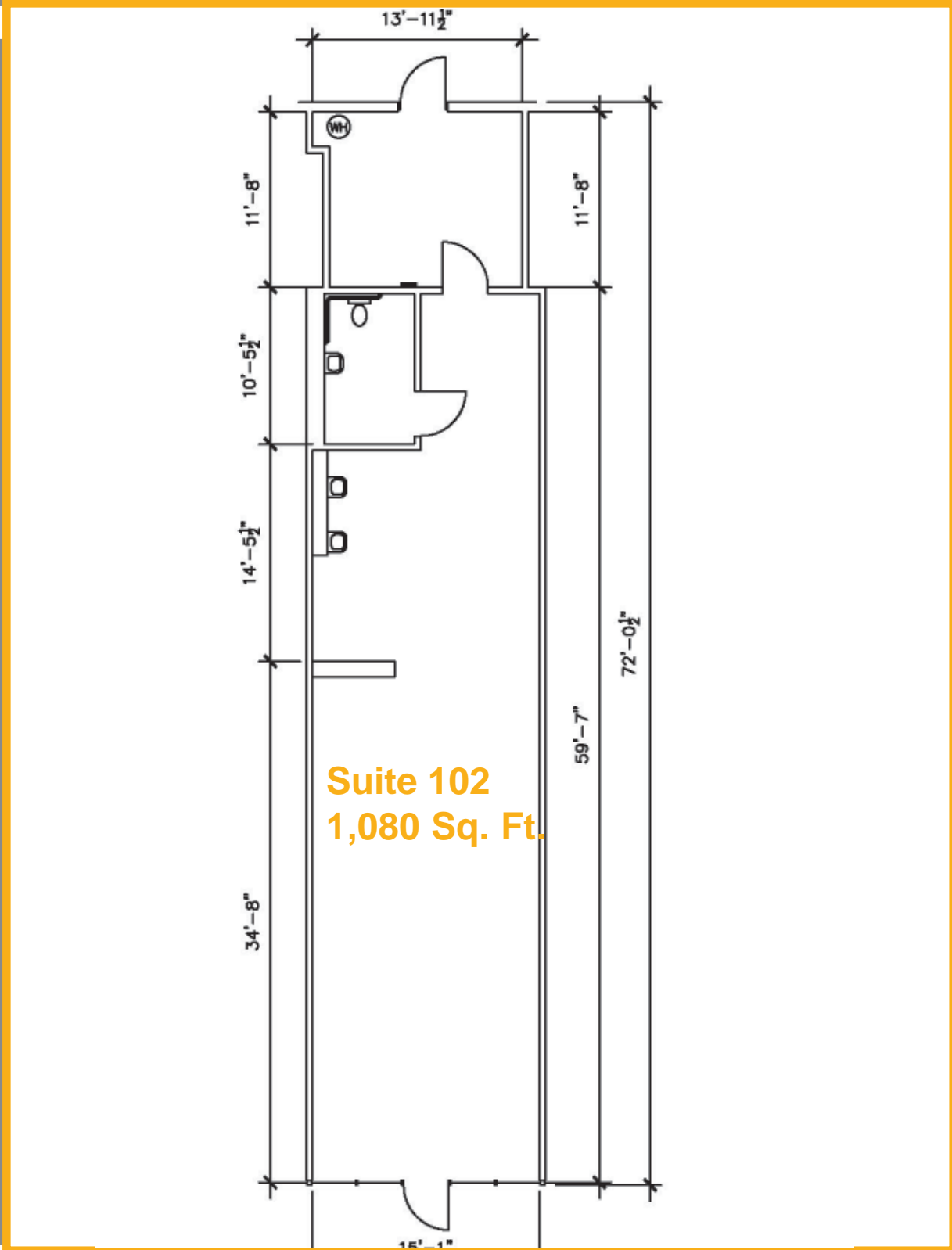

Suite 102
1,080 Sq. Ft.

All information regarding this property is from sources deemed reliable, however, Broker has not made an independent investigation of these sources and no warranty or representation is made by the Broker as to the accuracy thereof and same is submitted subject to errors, omissions, change of price, rental or other conditions, prior sale, lease or withdrawal from market without notice. Broker further has not made and shall not make any warranty or representation as to the condition of the property nor the presence of any hazardous substances or any environmental or other conditions that may affect the value or suitability of the property.

FOR LEASE

Retail Space
North Austin, Texas

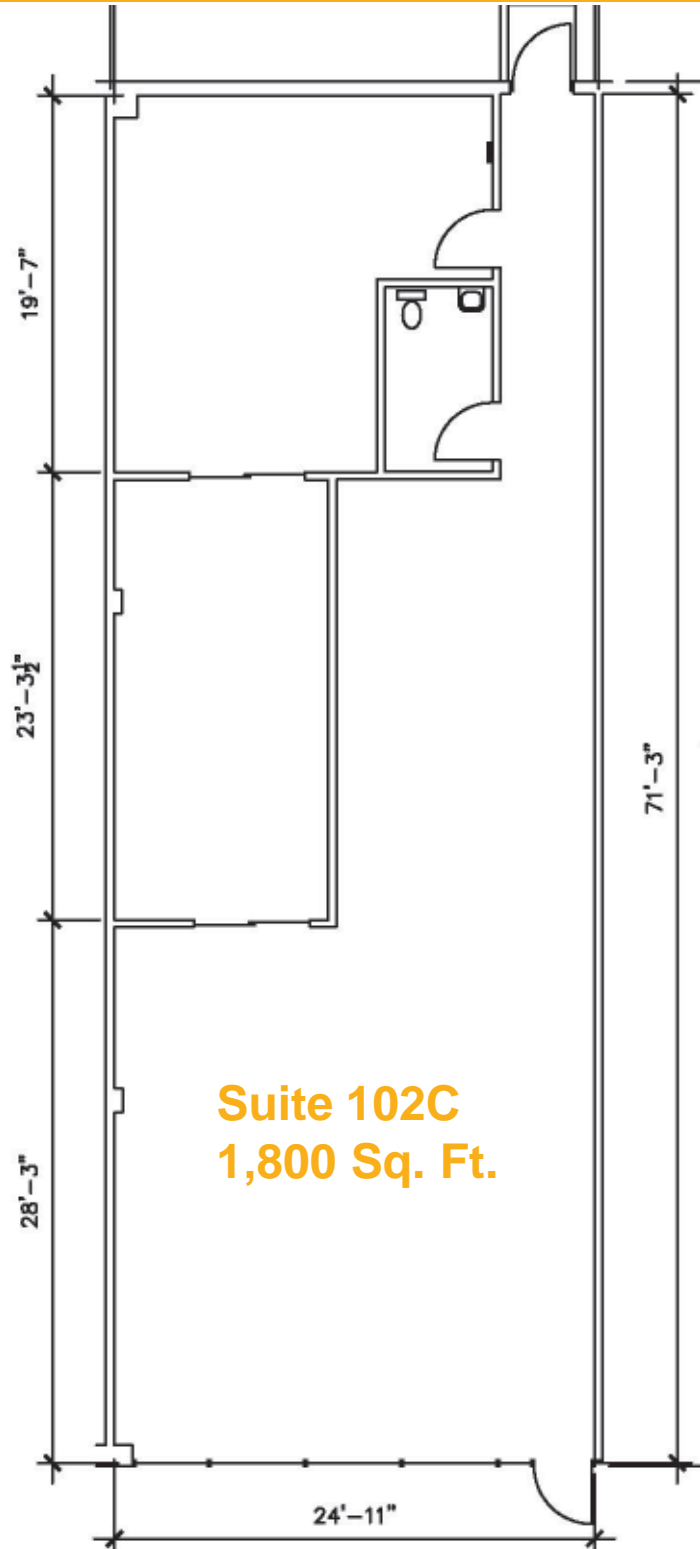

Suite 102C
1,800 Sq. Ft.

All information regarding this property is from sources deemed reliable, however, Broker has not made an independent investigation of these sources and no warranty or representation is made by the Broker as to the accuracy thereof and same is submitted subject to errors, omissions, change of price, rental or other conditions, prior sale, lease or withdrawal from market without notice. Broker further has not made and shall not make any warranty or representation as to the condition of the property nor the presence of any hazardous substances or any environmental or other conditions that may affect the value or suitability of the property.

1300 West Lynn, Suite 110, Austin, Texas 78703, (512) 474-2224 fax: (512) 474-4224

FOR LEASE

Retail Space
North Austin, Texas

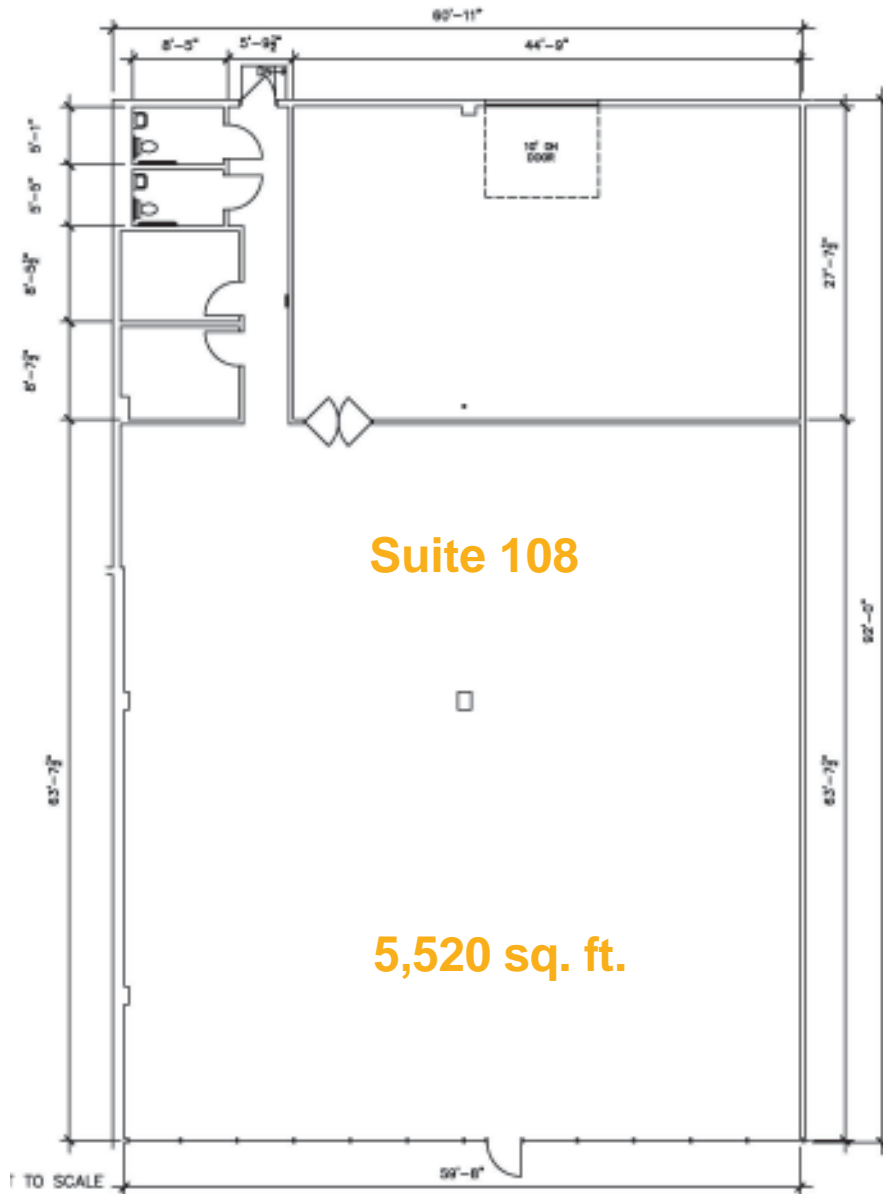

All information regarding this property is from sources deemed reliable, however, Broker has not made an independent investigation of these sources and no warranty or representation is made by the Broker as to the accuracy thereof and same is submitted subject to errors, omissions, change of price, rental or other conditions, prior sale, lease or withdrawal from market without notice. Broker further has not made and shall not make any warranty or representation as to the condition of the property nor the presence of any hazardous substances or any environmental or other conditions that may affect the value or suitability of the property.

DENTAL SPACE

2121 Parmer Lane , suite 111

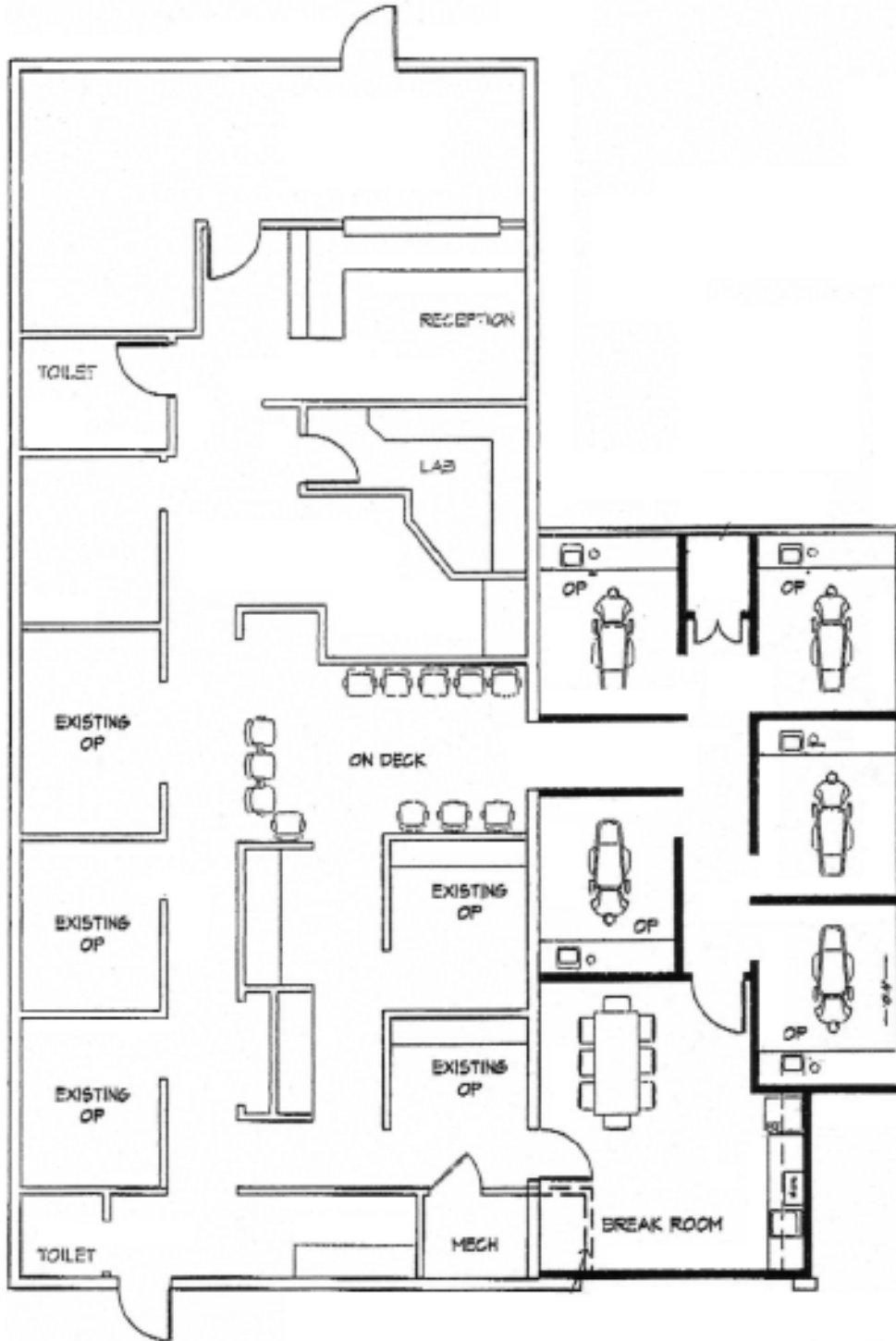

All information regarding this property is from sources deemed reliable, however, Broker has not made an independent investigation of these sources and no warranty or representation is made by the Broker as to the accuracy thereof and same is submitted subject to errors, omissions, change of price, rental or other conditions, prior sale, lease or withdrawal from market without notice. Broker further has not made and shall not make any warranty or representation as to the condition of the property nor the presence of any hazardous substances or any environmental or other conditions that may affect the value or suitability of the property.

1300 West Lynn, Suite 110, Austin, Texas 78703, (512) 474-2224 fax: (512) 474-4224

FOR LEASE

Retail Space
North Austin, Texas

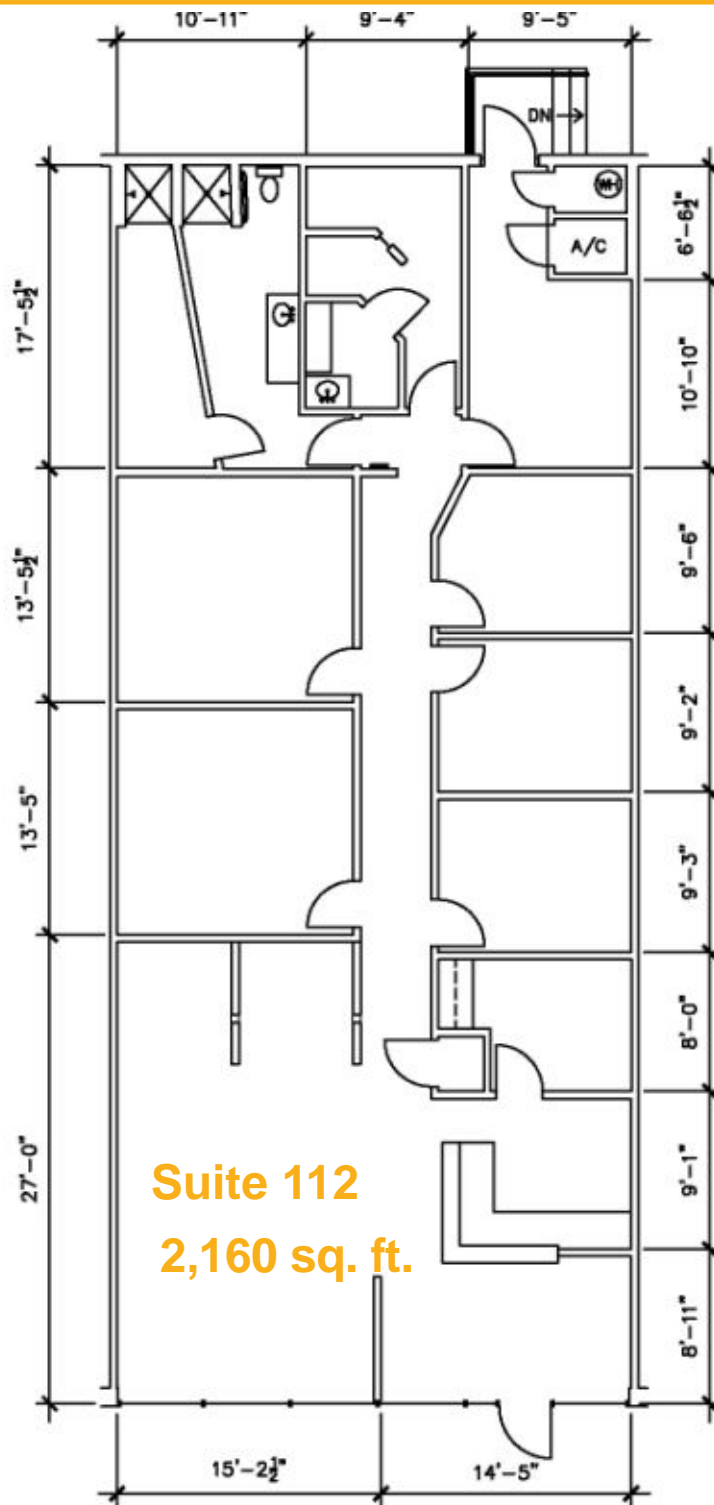

Suite 112
2,160 sq. ft.

All information regarding this property is from sources deemed reliable, however, Broker has not made an independent investigation of these sources and no warranty or representation is made by the Broker as to the accuracy thereof and same is submitted subject to errors, omissions, change of price, rental or other conditions, prior sale, lease or withdrawal from market without notice. Broker further has not made and shall not make any warranty or representation as to the condition of the property nor the presence of any hazardous substances or any environmental or other conditions that may affect the value or suitability of the property.

1300 West Lynn, Suite 110, Austin, Texas 78703, (512) 474-2224 fax: (512) 474-4224

FOR LEASE

Retail Space
North Austin, Texas

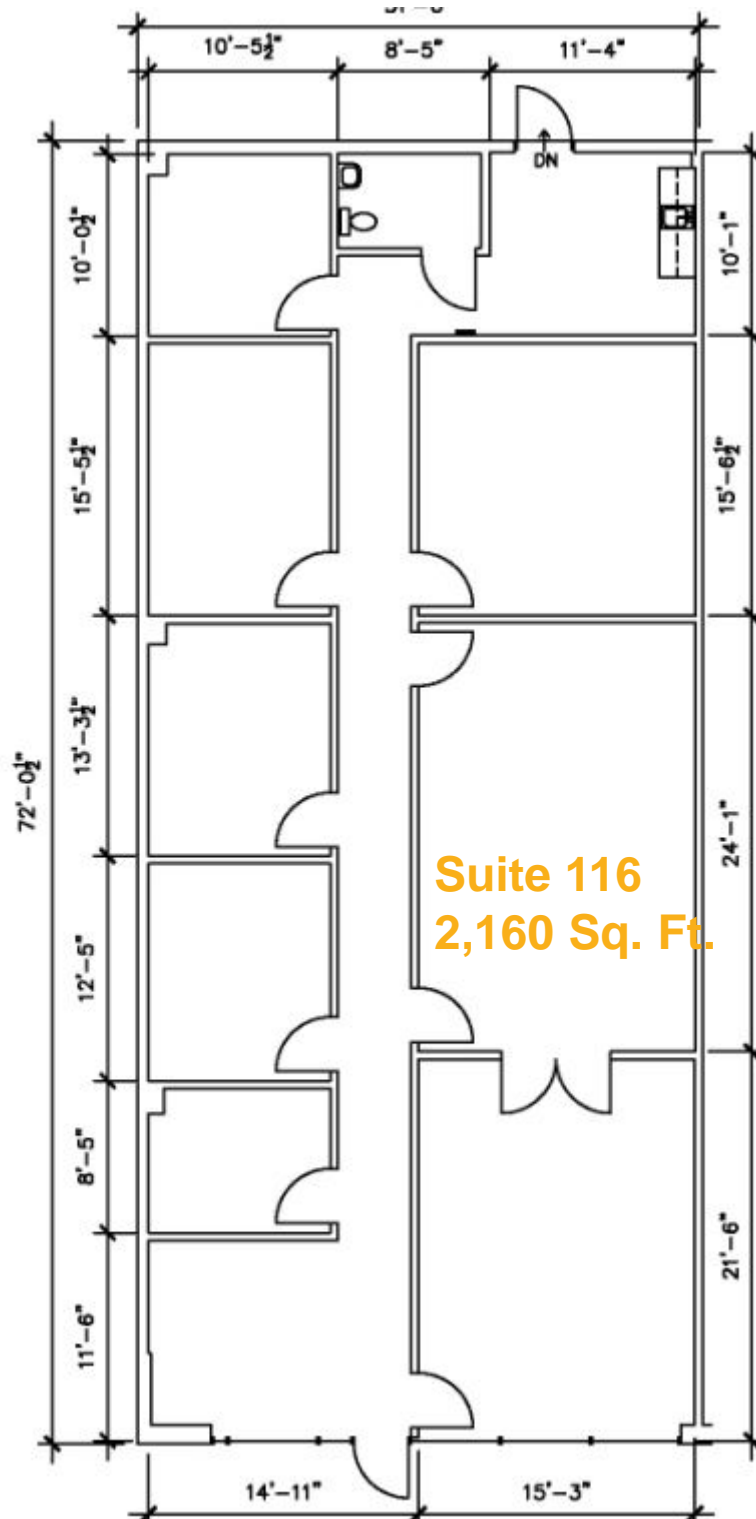

FOR LEASE

Retail Space
North Austin, Texas

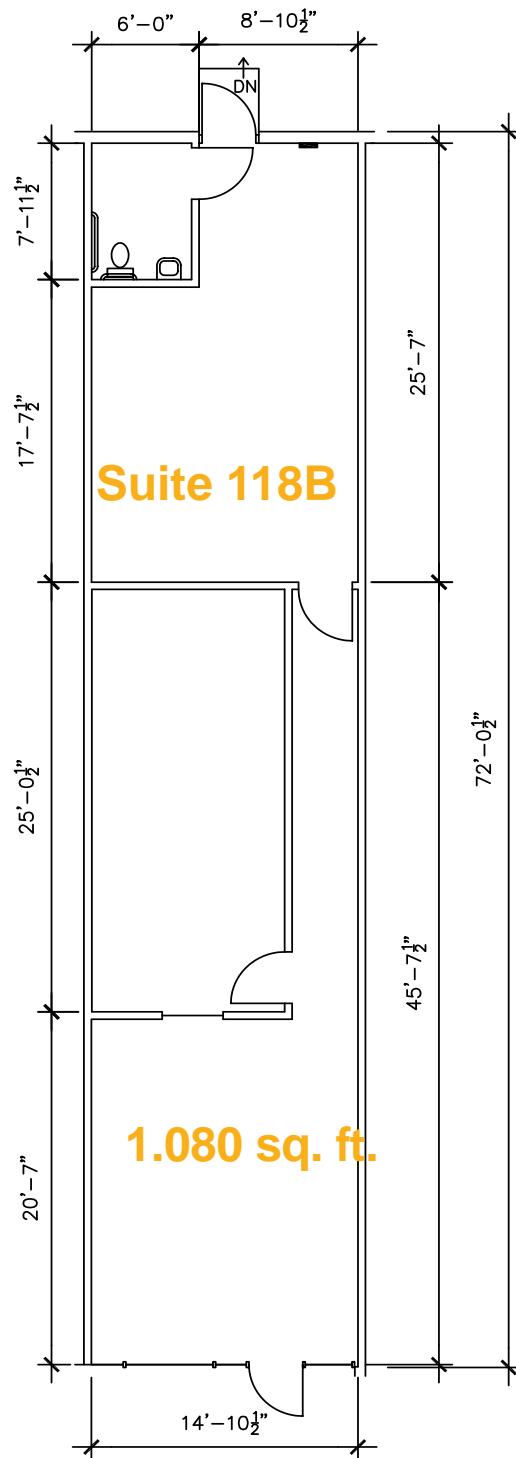

All information regarding this property is from sources deemed reliable, however, Broker has not made an independent investigation of these sources and no warranty or representation is made by the Broker as to the accuracy thereof and same is submitted subject to errors, omissions, change of price, rental or other conditions, prior sale, lease or withdrawal from market without notice. Broker further has not made and shall not make any warranty or representation as to the condition of the property nor the presence of any hazardous substances or any environmental or other conditions that may affect the value or suitability of the property.

FOR LEASE

Retail Space
North Austin, Texas

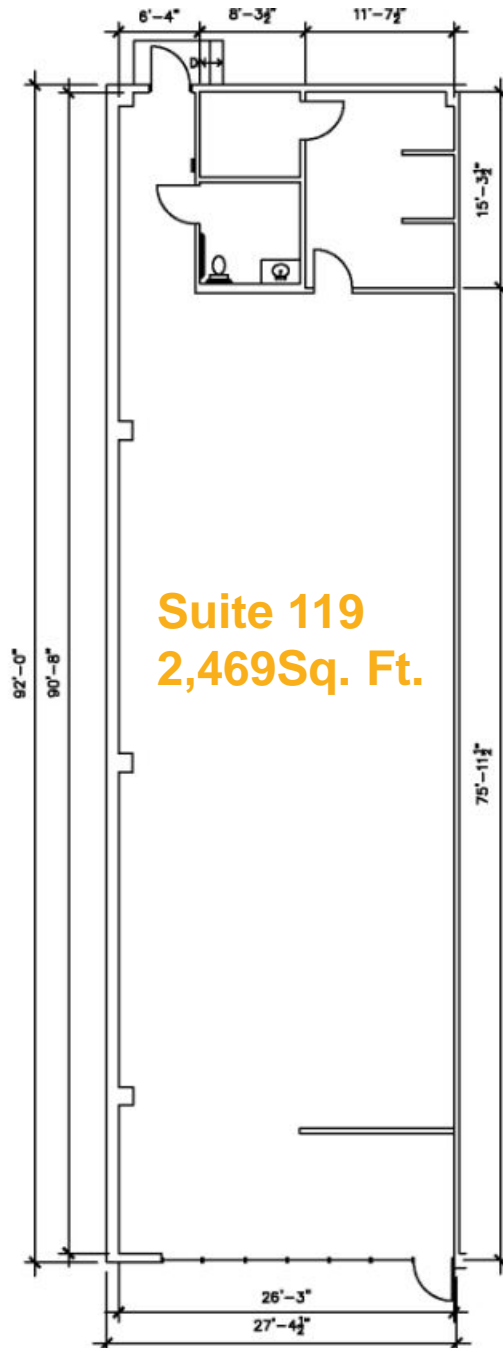

Suite 119
2,469Sq. Ft.

All information regarding this property is from sources deemed reliable, however, Broker has not made an independent investigation of these sources and no warranty or representation is made by the Broker as to the accuracy thereof and same is submitted subject to errors, omissions, change of price, rental or other conditions, prior sale, lease or withdrawal from market without notice. Broker further has not made and shall not make any warranty or representation as to the condition of the property nor the presence of any hazardous substances or any environmental or other conditions that may affect the value or suitability of the property.

1300 West Lynn, Suite 110, Austin, Texas 78703, (512) 474-2224 fax: (512) 474-4224